



The Chemical Company

SONOSHIELD HLM[®] 5000

Liquid cold-applied elastomeric waterproofing membrane system

Description

A one-component moisture-curing bitumen-modified polyurethane. HLM[®] 5000 forms a seamless elastomeric waterproofing membrane for exterior below-grade or between-slab applications.

Where to use HLM[®] 5000

- Above grade between two-course concrete and within cavity walls
- Exterior below grade on masonry, concrete, and incidental metal
- Parking garages
- Plaza decks and malls
- Fountains and pools
- Balconies and planters
- Bridges and highways
- Below-grade slabs
- Walls and culverts
- Sea walls, dams and reservoirs
- Concrete tanks
- Exterior plywood
- Inverted roof systems

Features

- Standard and high-build systems
- Waterproofs concrete
- Elastomeric

- Wide service temperature range
- Chemical resistant
- Seamless cold-applied membrane
- Asphalt-modified polyurethane

Benefits

- Specification versatility
- Protects structure from water penetration
- Permits expansion and contraction
- Suitable for all climates
- Resists bacterial attack, and many acids, alkalis, and salts
- Eliminates lapping, seaming, and precutting
- No hot-melt equipment required

Packaging

HLM[®] 5000 SL, HLM[®] 5000 S, and HLM[®] 5000 R are available in 18.95 litre pails; 208 litre drums are available on special order.

HLM[®] 5000 T is available in 18.95 litre pails only.

Standards

ASTM C 836

National standard of Canada 37.58 - M86 developed by CGSB



The Chemical Company

SONOSHIELD HLM[®] 5000

Typical properties

Properties listed are only for guidance and are not a guarantee of performance

Results shown are typical but are not intended as Tested in direction of greatest elongation of fabric.

HLM[®] 5000 (self-levelling grade)

Typical cured property*	High-Build system	Standard system
Shore 00 hardness, ASTM C 836	N/A	85
Viscosity, poise Brookfield		
HLM [®] 5000 SL	125	
HLM [®] 5000 S	450	
HLM [®] 5000 R	800	
HLM [®] 5000 T	4,000	
Tensile strength, psi ASTM D 412	200	150 ± 25
Average elongation, % ASTM D 412	300**	600
100% modulus, psi ASTM D 412	80	80 ± 10
Minimum recovery, %	90	90
Swelling in water, 3 days at room temperature	Nil	Nil
Service temp. range, °C	-40°C to 49°C	-40°C to 49°C
Moisture vapor permeability, perm inches dry		
	0.075	0.1
Crack bridging test: ASTM C 836 cycled 10 times per 24 hours at -9°C	Passed 1/4 inch No loss of bond or cracking exhibited	Passed 1/16 inch No loss of bond or cracking exhibited
Extensibility after heat aging ASTM C 836		No cracking
Adhesion in peel, lbs./inch (1 lb./inch min.) ASTM C 836	5	
Weight loss, % (20% max) ASTM C 836	16	

For best performance

HLM[®] 5000

- Apply HLM[®] 5000 when substrates are dry and air temperatures are between 4°C and 32°C; for application at temperatures below 4°C, consult BASF's Technical Services.
- Avoid application when inclement weather is present or imminent.
- Do not apply to reinforcing bars or to wet or contaminated surfaces.
- Protect HLM[®] 5000 coated surfaces from puncture with protection board until required topping or backfill is placed.
- If project schedule does not permit 14-day minimum cure of concrete, contact Technical Service for primer recommendations.
- Carefully work material over irregular concrete to avoid pinholes and holidays.
- Do not apply to surfaces treated with curing and parting compounds unless they have been completely removed chemically or mechanically.
- Not intended as an exposed or wearing surface.
- Do not use where a solvent odor is objectionable, e.g., near areas where food preparation or processing take place during the application.
- Specify wet or paper curing for concrete to be coated with HLM[®] 5000; avoid using liquid curing compounds except MASTERKURE 181.
- Before applying HLM[®] 5000, protect all drains and drain openings.
- Cold temperatures influence viscosity and handling characteristics of HLM[®] 5000: heat

SONOSHIELD HLM[®] 5000

increases and cold decreases the flow. Keep HLM[®] 5000 cool in hot weather and warm in cold weather.

- Do not directly heat containers with flame, stove, hot plate, or oven.
- Patch all voids and deep depressions in substrates with appropriate BASF patching material before applying HLM[®] 5000.
- Apply asphalt overlay in accordance with asphalt industry and manufacturer's standards.
- The HLM[®] 5000 membrane must be protected from heat, impact, and any other damage that could be caused by an asphalt overlay.

Order information

HLM[®] 5000 comes in a variety of grades for different applications.

- HLM[®] 5000 SL (self-leveling) is formulated for application by squeegee to horizontal areas.
- HLM[®] 5000 T (trowel) is formulated for application by trowel to vertical surfaces.
- HLM[®] 5000 S (spray) is a specially formulated version of 5000T for spray application.
- HLM[®] 5000 R (roller) is formulated for application by roller to vertical and some horizontal surfaces.
- Companion product to HLM[®] 5000 is PRIMER 733, used for priming metal to be covered by HLM[®] 5000, and SOLVENT NO. 2, used to clean tools and equipment.

Shelf life

Shelf life of HLM[®] 5000 is 6 months in unopened containers when stored in dry conditions between 4°C and 27°C. During storage, an easily removed skin of HLM[®] 5000 may form, which does not affect performance of the product.

Coverage

1.6 litres m² gives dft 1.3mm

Note: Coverage may vary with the application technique used. Actual coverage rate and thickness depend on finish and porosity of the substrate.

How to apply HLM[®] 5000

Surface preparation

For best results, all concrete deck surfaces should be lightly steel troweled to a fairly smooth finish. New concrete must be properly water cured at least 14 days. For extremely porous block, prime and coat with diluted HLM[®] 5000.

Remove dust, dirt, and other contaminants just before or during application. Surfaces must be dry at the time of application.

Air void pockmarks or honeycombs must be opened up to allow HLM[®] 5000 to fill the cavities completely. Air entrapment within voids may cause blisters. Extreme cases may require a parge coat.

Prestriping: Before applying the final membrane, all joints, cracks, and openings around protrusions must be sealed by caulking or prestriping (a preliminary coating of HLM[®] 5000 applied with a trowel or stiff bristle brush). Allow to dry overnight before applying final membrane. When the final membrane is applied, the overall thickness over joints and cracks, at coves and around penetrations should be approximately 2.5 mm on the standard system.

Static joints and cracks:

Joints and cracks less than 1.8 mm should be filled by pre-striping. Apply material so it both fills and overlaps the joint or crack to a width of 100 mm on each side.



The Chemical Company

SONOSHIELD HLM[®] 5000

Working or expansion joints:

All joints over 3mm must be sealed with a Sonolastic sealant. Any **working joint** less than 3mm should be routed to a minimum of 3mm and filled with a Sonolastic sealant. Prevent the waterproofing membrane from adhering to the joint sealant, which could cause sealant or membrane failure, by applying a coat of liquid household carnauba wax over the cured sealant and then prestriping.

Metal:

All metal must be wire brushed or sandblasted to bright metal. Prime with a quality rust-inhibiting metal primer and PRIMER 733 before application of HLM[®] 5000.

Vent, drain pipe, and post penetrations:

Clean metal surfaces to bright metal and prime with a quality rust-inhibiting metal primer followed by PRIMER 733. Remove dust, debris, and any other contaminants from voids. Seal with the appropriate Sonolastic sealant. Openings exceeding 3mm must first be sealed with Sonolastic sealant. Next, prestripe to a minimum width of 100mm on the base slab and continue up the penetration to the height of the top course wearing surface.

Application

Standard system*

For horizontal applications, simply empty contents of pail and spread immediately to ensure workability. Best results are obtained by marking off 11.61 m² areas and evenly spreading the contents of a 18.93 litres unit with a rubber-edged notched squeegee. Repeat the above procedure until the entire surface is covered. The above rate gives a wet film thickness of approx. 1.6mm.

Select the grade of HLM[®] 5000 that best meets individual job requirements. Use HLM[®] 5000 T for trowel application, HLM[®] 5000 S for spray application, HLM[®] 5000 R for roller application, or HLM[®] 5000 SL for squeegee application.

Verify the applied thickness with a wet film gauge as the work progresses.

The integrity of the cured membrane on a horizontal surface may be verified by damming the entire area and flooding with water to a minimum depth of 5mm and allowing the water to stand for 24-48 hours. Visually inspect the bottom surface, if possible to check for any water penetration. If repairs are necessary, the area should be drained and allowed to dry before reapplying HLM[®] 5000. After re-application, the area should be tested again for membrane integrity.

High-build system*

Apply 1.6mm wet thickness of HLM[®] 5000, followed by setting Sonoshield Reinforcing Fabric into the wet material. Overlap all seams a minimum of 76mm.

Allow the first coat to dry overnight and follow with a second 1.6mm wet application of HLM[®] 5000.

Spray equipment:

For spray equipment recommendations, consult the equipment manufacturer.

***Note: Finish coat must be applied in a pinhole-free, continuous membrane for waterproofing integrity.**

SONOSHIELD HLM[®] 5000

Curing

Appreciable properties develop within 24-48 hours at 24°C and 50% relative humidity. HLM[®] 5000 should be protected from traffic before placement of protection board and topping. Install tightly butted protection board (minimum 3mm thick) as soon as possible following cure of HLM[®] 5000.

Clean up

Clean all tools and equipment immediately after application with CLEANING SOLVENT NO. 2.

How to apply protection course II

Surface preparation

Waterproofing membranes must be protected against tear, puncture, and other abuses during placement of concrete wearing slabs and reinforcing steel. They should also be protected from job-site traffic and backfilling operations.

All specifications calling for membrane waterproofing should also require protection of membrane as an integral part of the overall waterproofing system.

Application

Install tightly butted BASF Protection Course II as soon as possible following cure of the liquid membrane. Protect HLM[®] 5000 from traffic before placement of protection board. HLM[®] 5000 must be cured before installation of any topping.

Where hot bituminous topping is to be applied over the 6mm thick protection board, cover the butt joints with flexible tape. Minimum topping thickness is 76mm, as recommended by the Asphalt Institute, in order to minimize crack reflection.

Detail drawing

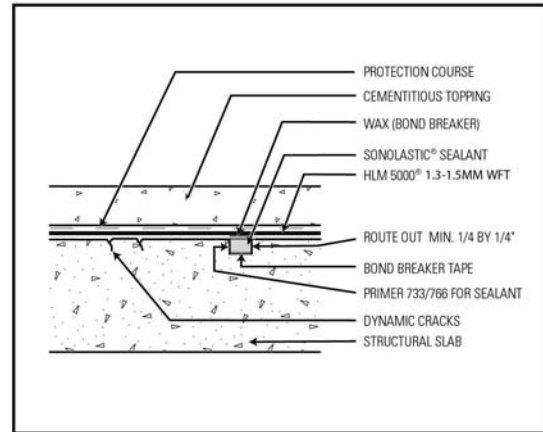

Dynamic Crack Detail

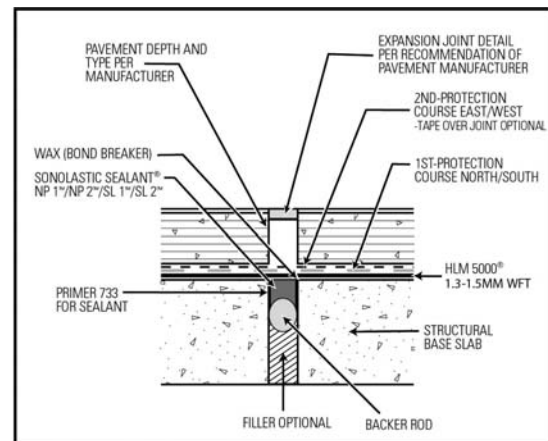

Asphalt Pavement Topping / Expansion Joint

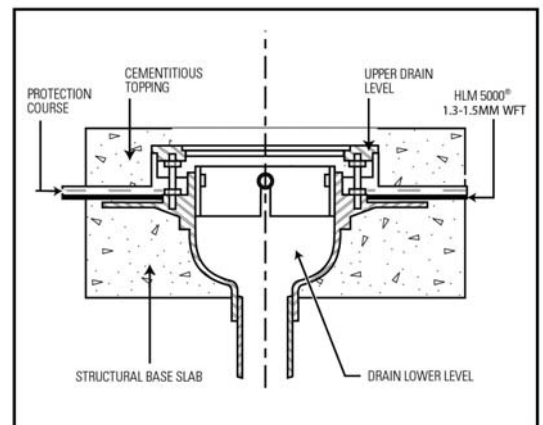

Waterproofing at Bi-Level Drain

SONOSHIELD HLM[®] 5000

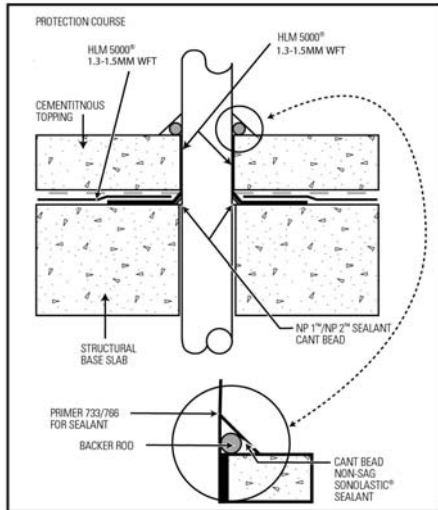

Vent / Drain / Pipe / Post Penetration Detail

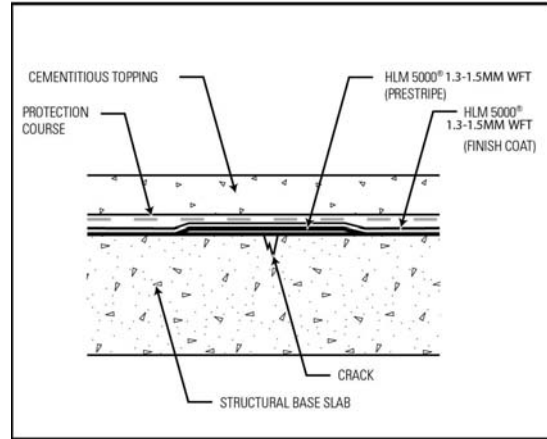

Static Crack / Prestripe Detail

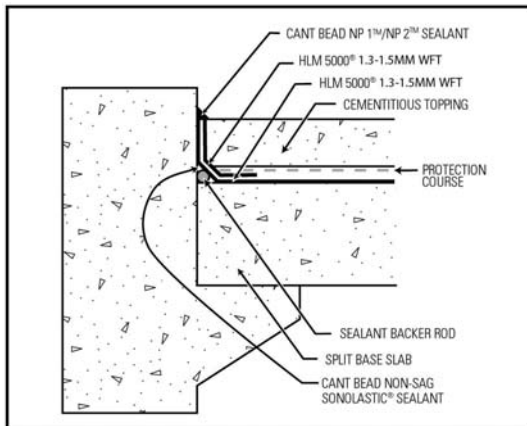

Split Slab with Cant Detail

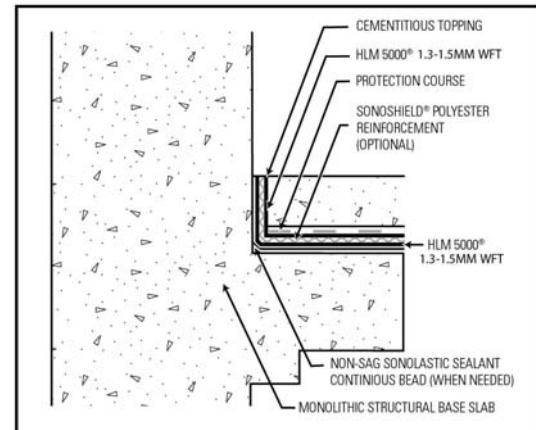

Inside Corner Detail (Static)

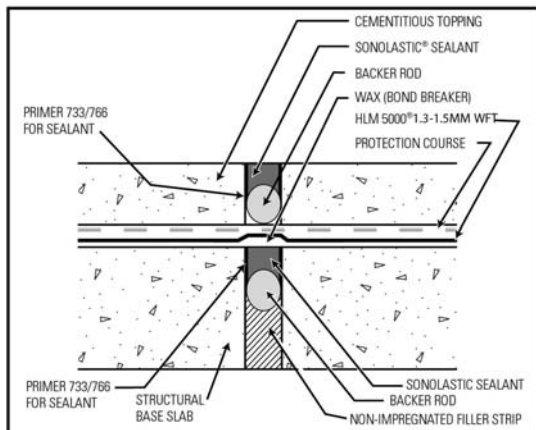

Expansion Joint Detail

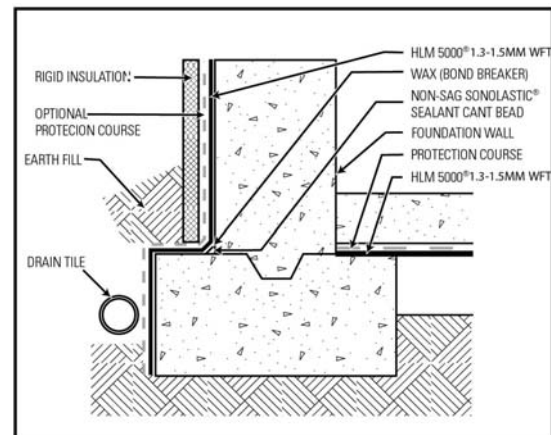

Waterproofing Foundation Walls



The Chemical Company

SONOSHIELD HLM[®] 5000

Warning

HLM[®] 5000 contains mineral spirits, naphtha-light aromatic, calcium oxide, toluene diisocyanate, silicon dioxide, talc, 1,2,4 trimethyl benzene, asphalt.

Risks

Combustible liquid and vapor. May cause skin, eye and respiratory irritation. May cause dermatitis and allergic responses. Potential skin and/or respiratory sensitizer. Ingestion may cause irritation of mouth, throat and stomach with nausea and abdominal pain. Reports associate repeated or prolonged occupational overexposure to solvents with permanent brain, nervous system, liver and kidney damage. INTENTIONAL MISUSE BY DELIBERATELY INHALING THE CONTENTS MAY BE HARMFUL OR FATAL.

Precautions

KEEP AWAY FROM HEAT, FLAME AND SOURCES OF IGNITION. KEEP OUT OF THE REACH OF CHILDREN. Keep container closed. Use only with adequate ventilation. Avoid contact with skin, eyes and clothing. Wash thoroughly after handling. Avoid breathing vapors. Use impervious gloves, eye protection and if the TLV is exceeded or if used in a poorly ventilated area, use NIOSH/MSHA approved respiratory protection in accordance with applicable federal, state and local regulations. Empty container may contain explosive vapors or hazardous residues. Do not cut or weld on or near empty container. All label warnings must be observed until container is commercially cleaned or reconditioned.

First aid

In case of eye contact, flush thoroughly with water for at least 15 minutes. SEEK IMMEDIATE MEDICAL ATTENTION. In case of skin contact, wash affected areas with soap and water. If irritation persists, SEEK MEDICAL ATTENTION. Remove and wash contaminated clothing. If inhalation causes physical discomfort, remove to fresh air. If discomfort persists or any breathing difficulty occurs, or if swallowed, SEEK IMMEDIATE MEDICAL ATTENTION. Refer to Material Safety Data Sheet (MSDS) for further information.

Proposition 65

This product contains materials listed by the state of California as known to cause cancer, birth defects or other reproductive harm.

VOC content

HLM[®] 5000 SL contains 18.3 g/L of coating. HLM[®] 5000 S contains 190 g/L of coating. HLM[®] 5000 R contains 180 g/L of coating. HLM[®] 5000 T contains 132 g/L of coating.

04/2000 BASF_CC-UAE revised 02/2005

Whilst any information contained herein is true, accurate and represents our best knowledge and experience, no warranty is given or implied with any recommendations made by us, our representatives or distributors, as the conditions of use and the competence of any labour involved in the application are beyond our control.

As all BASF technical datasheets are updated on a regular basis it is the user's responsibility to obtain the most recent issue.

BASF Construction Chemicals UAE LLC

P.O. Box 37127, Dubai, UAE

Tel: +971 4 8090800

www.basf-cc.ae

Fax: +971 4 8851002

e-mail: marketingcc.mideast@basf.com



Certificate No.
963680



Certificate No.
945787



Certificate No.
772556