



The Chemical Company

# MASTERFLOW<sup>®</sup> 885

## High strength metallic aggregate reinforced non-shrink, non-catalysed grout with load bearing properties

### Description

MASTERFLOW<sup>®</sup> 885 is a ready to use product in powder form, which requires only the on-site addition of water to produce a non-shrink, metallic reinforced grout of predictable performance.

### Applications

MASTERFLOW<sup>®</sup> 885 is formulated for use at any consistency from fluid to damp-pack, and may be used with confidence for grouting and precision bearing operations where shrinkage must be eliminated to achieve full bedding and load transfer.

- Turbines, generators and compressors.
- Rolling, stamping, drawing and finishing mills.
- Paper machine soleplates.
- Anchor bolts and rods.
- Machinery and equipment requiring high strength maximum bearing.

### Advantages

- Meets the compressive strength and non-shrink requirements of CRD-C 621, Corps of Engineers Specification for Non-shrink Grout.
- Hardens free of bleeding, settlement or drying shrinkage when mixed, placed and cured at any consistency - fluid, flowable, plastic or damp pack.
- Can be used at temperatures ranging from as high as 40°C to as low as 4°C when mixing and placing recommendations are followed.
- Designed for use where thermal movement of equipment and machinery and other effects of heating/cooling and wetting/drying are anticipated.

- Contains both metallic and quartz aggregates to provide high strengths and increased impact resistance under dynamic and repetitive loading.

### Packaging

MASTERFLOW<sup>®</sup> 885 is supplied in 25kg sacks.

### Application procedure

#### Preparation:

The surface onto which the grout is to be applied should be scabbled to remove laitance and expose aggregate. Do not use bush hammers or similar preparation equipment that can crush the aggregate but leave it in place. The surface must be free of oil, dust, dirt, paint, curing compounds, etc. Soak area to be grouted with water for 24 hours prior to grouting to minimise localised absorption and to assist in the free flow of the grout. Surfaces should be damp but free of standing water. Particular attention should be paid to bolt holes to ensure that these are water-free. Use oil free compressed air to blow out bolt holes and pockets as necessary.

Base plates, bolts, etc. must be clean and free of oil, grease and paint etc. Set and align equipment. If shims are to be removed after the grout has set, then lightly grease them for easy removal.

Ensure formwork is secure and watertight to prevent movement and leaking during the placing and curing of the grout. The area should be free of excessive vibration. Shut down adjacent machinery until the grout has hardened.

# MASTERFLOW<sup>®</sup> 885

In hot weather, base plates and foundations must be shaded from direct sunlight. Bags of grout should be stored in the shade prior to use.

In cold weather, the temperature of base plates and foundations should be raised to  $>10^{\circ}\text{C}$ .

## Mixing:

In hot weather use cool water to bring the mixed grout temperature to  $<30^{\circ}\text{C}$ .

In cold weather use warm water to raise the mixed grout temperature to  $>10^{\circ}\text{C}$ .

Damp down the inside of the grout mixer with water prior to mixing the initial batch of MASTERFLOW<sup>®</sup> 885. Ensure the mixer is damp but free of standing water. Add the pre-measured quantity of water. Slowly add the MASTERFLOW<sup>®</sup> 885 mixing continuously. Mix for at least five minutes until a smooth, uniform, lump free consistency is achieved.

## Placing:

Lengths of metal strapping laid in the formwork prior to placing may be necessary to assist grout flow over large areas and in compacting and eliminating air pockets. Pour the grout continuously. Maintain a constant hydrostatic head, preferably of at least 15 cm.

On the side where the grout has been poured, allow 10 cm clearance between the side of the form and the base plate of the machine.

On the opposite side allow 5-10 cm clearance between the formwork and the base plate.

## Shoulders

Due to differences in temperature between the

grout under the base plate, and exposed shoulders that are subject to more rapid temperature changes, debonding and / or cracking can occur. Avoid shoulders wherever possible.

If shoulders are required they should be firmly anchored with reinforcing to the substrate to prevent debonding.

MASTERFLOW<sup>®</sup> 885 grout is suitable for use with most types of pumping equipment.

Immediately after MASTERFLOW<sup>®</sup> 885 grout is placed, cover all exposed grout with clean wet hessian and keep moist by covering with polythene until grout surface is ready to be finished, or until final set. To maintain effective curing the use of a curing membrane from the MASTERKURE range is recommended.

## Flowable grouting techniques

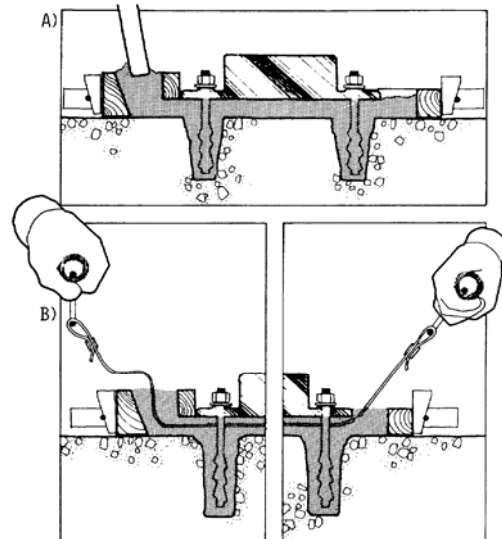

Diagram A illustrates the use of grout surcharge to ensure complete filling under a base.

Diagram B shows that straps can be used to aid grout flow under a wider base. A gentle "sawing"



The Chemical Company

# MASTERFLOW<sup>®</sup> 885

action with the strap allows the grout to flow without segregation for greater distances.

## Estimating data

Properties listed are only for guidance and are not a guarantee of performance

Consistency	Approximate yield (m <sup>3</sup> per 25kg bag)			
	Fluid	Flowable	Plastic	Damp pack
Temp. 25°C	0.0117	0.0115	0.0110	0.0105

## Water demand\*

Actual water demand will depend on consistency required and the temperatures (both ambient and grout). Do not use too much water as it will cause grout to bleed or segregate.

The following indicates the appropriate quantity of water required to mix a 25kg bag of MASTERFLOW<sup>®</sup> 885 grout to various consistencies at the temperature shown

- (1) 30 seconds flow by Corps of Engineers Flow Cone method
- (2) 400mm flow after 1 minute by Colcrete flow trough
- (3) 90% flow on flow table, ASTM C-230, 5 drops in 3 seconds

**UNDER NO CIRCUMSTANCES SHOULD MASTERFLOW<sup>®</sup> 885 BE RETEMPERED BY THE LATER ADDITION OF WATER.**

When a very rapid set is required in areas subject to chemical spillage or contamination, use epoxy grouts MASTERFLOW<sup>®</sup> 400/410.

For extreme chemical resistance grout, products are available from the MASTERFLOW<sup>®</sup> range.

For additional information on MASTERFLOW<sup>®</sup> 885 grout or other non-shrink grouting materials, contact your BASF representative.

## Safety precautions

As with other products containing Portland cement, the cementitious material in MASTERFLOW<sup>®</sup> 885 grout may cause irritation. Avoid contact with the eyes and prolonged irritation. In case of contact with the eyes, immediately flush with plenty of water for at least 15 minutes. Call a physician. In case of contact with skin, wash skin thoroughly.

## Storage

Store out of direct sunlight, clear of the ground on pallets protected from rainfall. Avoid excessive compaction.

Failure to comply with the recommended storage conditions may result in premature deterioration of the product or packaging. For specific storage advice consult BASF's Technical Services Department.

## Note

Field service, where provided, does not constitute supervisory responsibility. For additional information contact your local BASF representative.

BASF reserves the right to have the true cause of any difficulty determined by accepted test methods.



The Chemical Company

# MASTERFLOW<sup>®</sup> 885

## Quality and care

All products originating from BASF's Dubai, UAE facility are manufactured under a management system independently certified to conform to the requirements of the quality, environmental and occupational health & safety standards ISO 9001, ISO 14001 and OHSAS 18001.

02/94 BASF\_CC-UAE revised 09/2004

REQUEST AND REFER TO RECOMMENDED INSTALLATION PROCEDURES FOR <b>MASTERFLOW<sup>®</sup></b> GROUTS PRIOR TO USE
--

---

Whilst any information contained herein is true, accurate and represents our best knowledge and experience, no warranty is given or implied with any recommendations made by us, our representatives or distributors, as the conditions of use and the competence of any labour involved in the application are beyond our control.

**As all BASF technical datasheets are updated on a regular basis it is the user's responsibility to obtain the most recent issue.**

---

### BASF Construction Chemicals UAE LLC

P.O. Box 37127, Dubai, UAE

Tel: +971 4 8090800

www.basf-cc.ae

Fax: +971 4 8851002

e-mail: marketingcc.mideast@basf.com



Certificate No.  
963680



Certificate No.  
945787



Certificate No.  
772556